

Amarillo Single Reduction Gear Boxes

155 Single Reduction

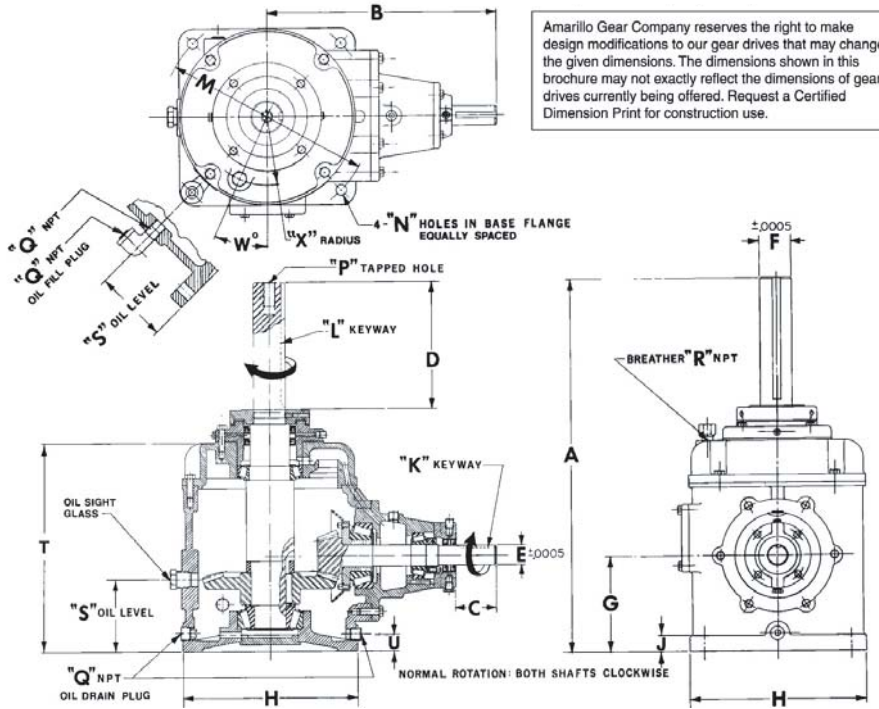

Amarillo Gear Company reserves the right to make design modifications to our gear drives that may change the given dimensions. The dimensions shown in this brochure may not exactly reflect the dimensions of gear drives currently being offered. Request a Certified Dimension Print for construction use.

| A | B | C | C with non-reverse | D | E | F | G | H | J | K | L | M | N |
|----------|---------|-------|--------------------|-------|-------|-------|-------|----|-------|------------|-----------|----|-------|
| 31 11/16 | 23 1/16 | 3 7/8 | 2 1/2 | 9 1/2 | 1.874 | 2.999 | 9 1/2 | 19 | 1 1/4 | 3/8 X 3/16 | 3/4 x 3/8 | 22 | 13/16 |

| P | Q | R | S | T | U | W | X | WEIGHT |
|-----------|-----|-----|---|--------|-------|----|-------|--------|
| 3/4 -10NC | 3/4 | 1/2 | 7 | 19 3/4 | 1 3/8 | 54 | 6 3/8 | 675 |

| Exact Ratio | | | | | | | | | | | | | | | | | | | |
|-------------|-----|---|-----|-----|-----|------|------|------|------|------|------|------|------|------|------|------|------|------|-----|
| 2 | 2.5 | 3 | 3.3 | 3.5 | 3.8 | 4 | 4.3 | 4.5 | 4.8 | 5 | 5.5 | 6 | 6.5 | 7 | 7.5 | 8 | 8.5 | 9 | 9.5 |
| | | | | | | 4.00 | 4.21 | 4.54 | 4.77 | 5.08 | 5.58 | 6.00 | 6.56 | 7.11 | 7.50 | 8.00 | 8.50 | 9.00 | |

| Domestic Shipping Weight (lbs) | Weight with Export Boxing (lbs) | Export Box Dimensions (L, x W x H) (in) | Vertical Shaft Down Thrust Capacity (pounds) | 4700 | Thrust ratings vary greatly depending upon the transmitted power and the vertical shaft speed. The rating to the left are the axial loads that can be applied the fan shaft which will always result in a calculated bearing life greater than 100,000 hours. These ratings are based on the worse case from the power rating tables. All models can be supplied with larger thrust bearings or special bearing arrangements. Contact us when the fan loading conditions or the bearing life requirements cannot be satisfied with the ratings from the table. |
|--------------------------------|---------------------------------|---|--|------|--|
| 705 | 855 | 40 x 27 x 41 | | | |

Service Horsepower Ratings (Service Factor =2.0) RATIO*

| Input RPM | 2 | 2.5 | 3 | 3.3 | 3.5 | 3.8 | 4 | 4.3 | 4.5 | 4.8 | 5 | 5.5 | 6 | 6.5 | 7 | 7.5 | 8 | 8.5 | 9 | 9.5 |
|-----------|---|-----|---|-----|-----|-----|-----|-----|-----|-----|-----|-----|----|-----|----|-----|----|-----|----|-----|
| 1750 | | | | | | | 133 | 125 | 119 | 114 | 110 | 100 | 90 | 85 | 75 | 65 | 55 | 50 | 45 | |
| 1450 | | | | | | | 110 | 104 | 99 | 94 | 91 | 83 | 75 | 70 | 62 | 54 | 46 | 41 | 37 | |
| 1160 | | | | | | | 88 | 83 | 79 | 76 | 73 | 66 | 60 | 56 | 50 | 43 | 36 | 33 | 30 | |

*Choose models & Ratios in outlined area for standard price and delivery. Contact us for all others.

| | PROJECT NAME AND LOCATION: | THIS DRAWING IS THE SOLE PROPERTY OF COOLING TOWER DEPOT INC. USE SHALL BE LIMITED TO THE PROJECT FOR WHICH IT IS INTENDED. NO REPRODUCTION SHALL BE MADE NOR SHALL THIS INFORMATION BE MADE AVAILABLE TO THIRD PARTIES WITHOUT THE PRIOR WRITTEN CONSENT BY COOLING TOWER DEPOT INC. ANY AND ALL PROPRIETARY RIGHTS TO THIS INFORMATION AND DESIGN ARE THE SOLE PROPERTY OF COOLING TOWER DEPOT INC. | | | | | | | | | | | | | | | | | | | | | | | | | | | | | | | | | | | | | | | |
|-----------------------|--|---|--------------|-------------|--------------|-------|--|--|--|--|-----------------|----------|-------------|--------------|-------------|--------------|-------|--|--|--|--|--|--|--|--|--|--|--|--|--|--|--|--|--|--|--|--|--|--|--|--|
| | MODEL NO.: | <table border="1"> <tr> <th>REV.</th> <th>DESCRIPTION</th> <th>DESIGNED BY:</th> <th>CHECKED BY:</th> <th>APPROVED BY:</th> <th>DATE:</th> </tr> <tr> <td> </td> <td> </td> <td> </td> <td> </td> <td> </td> <td> </td> </tr> <tr> <td> </td> <td> </td> <td> </td> <td> </td> <td> </td> <td> </td> </tr> <tr> <td> </td> <td> </td> <td> </td> <td> </td> <td> </td> <td> </td> </tr> <tr> <td> </td> <td> </td> <td> </td> <td> </td> <td> </td> <td> </td> </tr> </table> | | | | | | | | | | REV. | DESCRIPTION | DESIGNED BY: | CHECKED BY: | APPROVED BY: | DATE: | | | | | | | | | | | | | | | | | | | | | | | | |
| | REV. | DESCRIPTION | DESIGNED BY: | CHECKED BY: | APPROVED BY: | DATE: | | | | | | | | | | | | | | | | | | | | | | | | | | | | | | | | | | | |
| | | | | | | | | | | | | | | | | | | | | | | | | | | | | | | | | | | | | | | | | | |
| | | | | | | | | | | | | | | | | | | | | | | | | | | | | | | | | | | | | | | | | | |
| | | | | | | | | | | | | | | | | | | | | | | | | | | | | | | | | | | | | | | | | | |
| | | | | | | | | | | | | | | | | | | | | | | | | | | | | | | | | | | | | | | | | | |
| DWG NAME: | <p align="center">COOLING TOWER DEPOT, INC 651 CORPORATE CIRCLE, STE. 206 GOLDEN, CO 80401 720-746-1234</p> | | | | | | | | | | | | | | | | | | | | | | | | | | | | | | | | | | | | | | | | |
| DRAWING NUMBER: A-100 | JOB NUMBER: | SHEET: 1 of 1 | REV: 0 | NO SCALE | | | | | | | SCALE: NO SCALE | NO SCALE | | | | | | | | | | | | | | | | | | | | | | | | | | | | | |